

Organisational Information

Sign up at: www.ecpe.org/events

Registration Deadline:

2 September 2025

Participation Fee:

- € 450,-* for industry
- € 320,-* for universities/institutes
- € 140,-* for students/PhD students

(limited spaces; copy of students ID required)

* plus VAT

- The regular participation fee includes lunch, coffee/soft drinks and digital proceedings.
- Digital proceedings will be provided by download link latest one day before start of the event. A printed handout is available on request (€ 50,-*).
- Upon receipt of registration confirmation via email you are signed-up for the event. The invoice will be sent via email.
- 25 % discount for participants from ECPE member companies. 10 % discount for participants from ECPE competence centres.
- Further information (hotel list and maps) will be provided after registration and can be found on the ECPE web page.
- Cancellation policy: Full amount will be refunded in case of cancellation upon to 2 weeks prior to the event. After this date 50 % of the fee is non-refundable (replacement is possible).
- The number of participants is limited to 8 attendees. We reserve the right to cancel the event or offer it as an online-only event if the minimum number of participants is not reached.

Organisational Information

Organiser ECPE e.V.
Ostendstrasse 181
90482 Nuremberg, Germany
www.ecpe.org

Technical Contact Dr. Chris Gould
+49 911 81 02 88 – 21
chris.gould@ecpe.org

Technical Chair Dr. Peter Türkes, Consultant (DE)

Organisation Angela von der Grün, ECPE e.V.
+49 911 81 02 88 – 17
angela.vondergruen@ecpe.org

Venue ECPE e.V.
Ostendstraße 181 (rear building)
90482 Nuremberg
Germany



Source photo: Löser & Partner Planungsgesellschaft mbH
Source photo front page: Peter Türkes



European Center for
Power Electronics e.V.

ECPE/Cluster Tutorial

Use and Assessment of Power Device Models in Power Electronics Simulation

9 September 2025

Nuremberg,
Germany

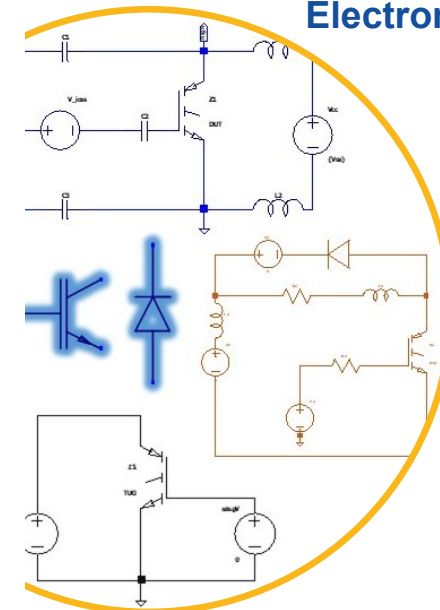

Use and Assessment of Power Device Models in Power Electronics Simulation

9 September 2025
Nuremberg, Germany

Some manufacturers of power devices are providing compact simulation models of their products. The intention of these compact models is supporting the customer who might use them for virtual prototyping purposes. Using 'Virtual Prototyping' in power electronics aims at the acceleration of the system development process. Therefore, the applied power device models have to have a high-level accuracy. This 'hands on training' shall enable you to evaluate and use compact power device models. It focuses onto IGBTs, Diodes and MOSFETs. It starts with a brief description of available power device models and the related data sheets. Both are available from the website of various vendors. Furthermore, a short introduction to the recommended simulation software LTSPICE (available from the 'Analog Devices' website for educational purposes https://www.analog.com/en/design-center/de_sign-tools-and-calculators/ltspice-simulator.html#) will follow.

During the course of this training, you will work through standard data sheet related simulation circuits and assess the used models in terms of correlation to the data sheet values. To evaluate the performance of power device models you will finally work through some application circuits. Simplifying the necessary drive and control circuits by controlled sources make this application circuits easy to handle.

Who should attend? Engineers, starting their career in power circuit design or simulation; device developers interested in power electronic system evaluation; students with a background in power electronics. The attendees should have LTSPICE on their notebook ready to use. Model libraries and test circuits needed for this tutorial will be distributed in advance.

Course Instructor:

Dr. Peter Türkes, Consultant (DE)

All presentations and discussions will be in English.

Content

1. Introduction to 'Power Device Models'

The different implementation levels of power device models are briefly explained. These model levels range from pure behavioural to physics based implementations. All of these model levels have as well advantages as disadvantages.

2. Becoming acquainted with LTSPICE by Simulating Data Sheet Characteristics

The most essential data sheet characteristics of IGBTs, MOSFETs and Diodes are compared to simulated curves in order to evaluate the device models performance:

- DC output and transfer characteristics; dependent on temperature
- Gate charge and capacitance curves
- Transient switching characteristics like switching times and losses; dependent on temperature and the particular operating condition

This task requires power device models from different manufacturers and the data sheet of the related devices.

3. Applying Power Device Models to Typical Applications

A typical switching characteristic circuit – the 'Chopper' circuit – is the core of most power conditioning and drive applications.

Buck- and Boost-converters or H-Bridge circuits can be derived from the chopper topology by the addition of PWM drivers.

Examples of application circuits are included in the tutorial documentation and will be explained briefly.

Programme

Tuesday, 9 September 2025

09:00 Registration & Welcome Coffee

09:20 Welcome, Opening
Chris Gould, ECPE e.V.

09:30 Configuring the Training Environment on LTSPICE
- The training file system and its content
- Basic handling of LTSPICE / introduction to the GUI

09:50 Introducing Power Device Models
- Availability of LTSPICE and PSPICE models
- Implementation variants of power device models
- Handling of power device models in the LTSPICE environment

10:10 Basic Demonstration
- Set up of a transfer curve characterisation circuit with the 'Schematic Capture'
- Defining the simulation controls
- Running the simulation
- Extracting the simulation results with the 'Waveform Viewer'

10:30 Coffee Break

11:00 Hands-on Training with Demonstration Circuits
- DC characteristics of power devices (IGBT, MOSFET, Diode)

11:45 Hands-on Training with Demonstration Circuits
- Gate charge and capacitance evaluation circuits

12:30 Lunch

13:30 Hands-on Training with Demonstration Circuits
- Transient characteristics of diodes
- Transient characteristics of power transistors

14:30 Coffee Break

15:00 Hands-on Training with Demonstration Circuits
- Simple PWM driver with controlled voltage / current sources
- Single ended resonant topology with two point current control (induction cooker)
- H-Bridge with PWM control

16:30 Feedback

17:00 End of Training