



The European Power Electronics Network ■

- Joint Research
- Advanced Training
- Public Relations



ECPE
European Center for Power Electronics e.V.

Landgrabenstrasse 94
90443 Nuremberg
Germany

Phone: +49 (0)911/8102 88-0
Fax: +49 (0)911/8102 88-28

E-mail: info@ecpe.org

Web: www.ecpe.org

ECPE Annual Event ■

CIPS - International Conference on Integrated Power Electronics Systems



■ The International Conference on Integrated Power Electronics Systems (CIPS) is organized biennially by VDE and ECPE in the frame of the ECPE Annual Event. Since the first CIPS in 1999, this conference has been focused on the integration of hybrid and mechatronic systems with high power density and systems' or components' operational behavior and reliability.

» ECPE the Industry-driven Research Network for Power Electronics; the leading European Technology and Innovation Platform; a strong voice of the Power Electronics community in Europe to the public and to politics! «

ECPE SiC & GaN User Forum 'Potential of Wide Bandgap Semiconductors in Power Electronic Applications'



■ The SiC & GaN User Forum is a Flagship of the ECPE Workshops. For more than 12 years, the potential of wide-bandgap power semiconductors for different applications has been discussed in this forum that takes place every two years. Renowned experts from industry and academia show the current state of the art and future trends, as well as current research and development work. With more than 300 participants it has become a valuable platform established for the exchange of experience.

Networking Platform ■

ECPE Joint Stand at PCIM Europe Exhibition



■ ECPE has been organizing a Joint Stand with Network Members at PCIM Europe Exhibition since 2005. In the last few years this 210 sqm stand has developed into a popular meeting point of our Network members at PCIM exhibition. Major highlights are the get-together of Network members and the ECPE Students Day.



ECPE Network Meetings



■ In the ECPE power electronics community of Member companies and Competence Centres, the ECPE Network Meetings offer a networking platform for exchange and discussion of trends and strategic topics. Recently addressed trends in Power Electronics and in the ECPE Network:

- the future of power electronics incl. the role of Artificial Intelligence (AI) - What comes next after wide bandgap devices and fast switching as well as after efficient and compact converters? What is the future role and impact of AI in Power Electronics?
- potential and limitations of hydrogen and fuel cells - mobility and transport beyond the limits of battery electric solutions; grid services and large-scale energy storage to buffer the fluctuating renewable energies from PV and wind power to enable a successful energy transition
- the role of power electronics in the upcoming energy transition towards an electricity grid dominated by power electronics on the generation side as well as on the load side
- digitalization driven by the fusion of power electronics and information & communication technologies including the problem of cybersecurity of energy systems

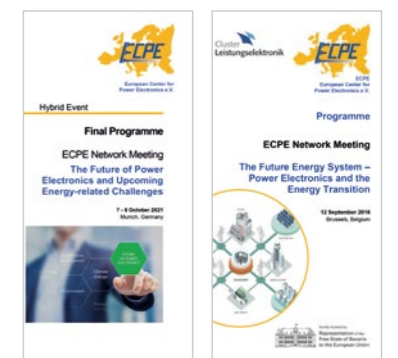

ECPE Network

ECPE European Center for Power Electronics e.V., founded in 2003 is the leading industry-driven Research Network in the field of Power Electronics in Europe with more than 200 member organizations, comprising Member companies and Competence Centres.

As a European technology and innovation platform, ECPE is driving precompetitive joint research and set up research & technology roadmaps for a strategic research agenda with future research directions according to the demands of European power electronics industry. The ECPE expert workshops and advanced training programme cover a wide range of current topics addressed especially to engineers from industry.

Precompetitive Joint Research

Network-internal research is organized in the ECPE Joint Research Programme focussing mainly on power electronics in automotive and industrial systems as well as for renewable energies and smart grids.

Advanced Training

ECPE Workshops and Tutorials address a wide range of up-to-date topics targeted especially at engineers in industry. In addition, a power electronics online course is available on the ECPE web site for members.

Public Relations

The ECPE public relations and lobbying activities to increase awareness of the role and importance of power electronics for Europe have two main directions, publicly funded research programmes addressing power electronics topics and future young engineers.

Join ECPE

Do you want to become part of the leading Industry-driven Research Network for Power Electronics in Europe?

For more information about membership please contact **Sabrina Haberl** (Member Service) or **Thomas Harder** (General Manager). See contact details on page 11.

Network Services



ECPE Workshops

The ECPE Workshops are addressing a wide range of up-to-date topics along the innovation and value chain of power electronics from materials, components and integration technologies up to system-related topics in various

application fields of power electronics e.g. in automotive, industrial drives, renewable energies and electronic power grids. These two-day Workshops provide a unique platform for networking talks and expert discussion.

Range of recent topics:

- EV-Charging Infrastructure
- Hardware in the Loop
- Capacitors in Power Electronics
- Steps towards Design Automation and Artificial Intelligence in Power Electronics
- Power Electronics Developments for Data Centres
- High Power Electronics for a Successful Energy Transition towards 100% Renewable Energy
- Design, Technology, Simulation and Application Aspects of Magnetic Components in Power Electronics



Free of charge for ECPE Member companies (3 seats)

ECPE Tutorials

Whilst the Workshops are mainly focussing on expert discussion, the ECPE Tutorials are addressing education and advanced training, with the target of helping engineers in industry entering a new job or function. The number of participants of these two-day courses is normally limited to 35 persons to keep the classroom atmosphere.

The portfolio of ECPE Tutorials is covering the basic topics and disciplines of power electronics: power semiconductor technologies and devices, power electronics packaging, EMC, reliability and thermal engineering.

Furthermore, ECPE is offering practical lab courses in cooperation with Competence Centres e.g. on 'EMC Optimized Design' with Fraunhofer IZM in Berlin.

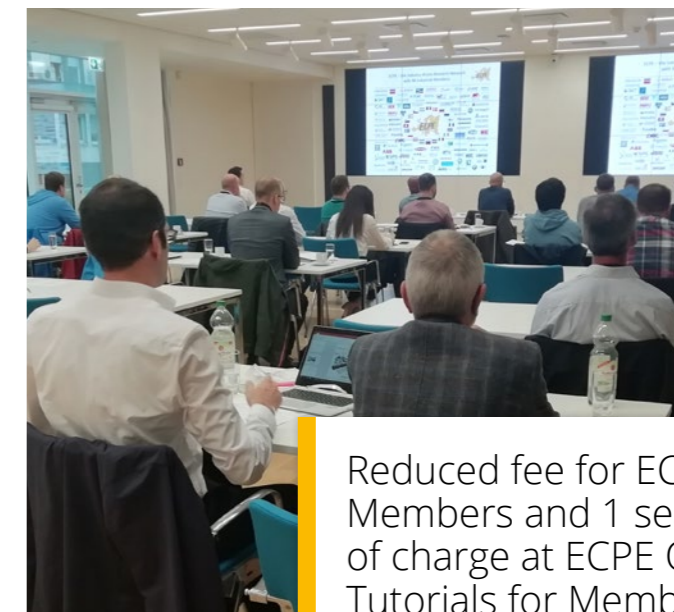

Reduced fee for ECPE Members and 1 seat free of charge at ECPE Online Tutorials for Member Companies

All programmes and registration forms are available on: www.ecpe.org/events

ECPE Member Companies



ECPE Competence Centres

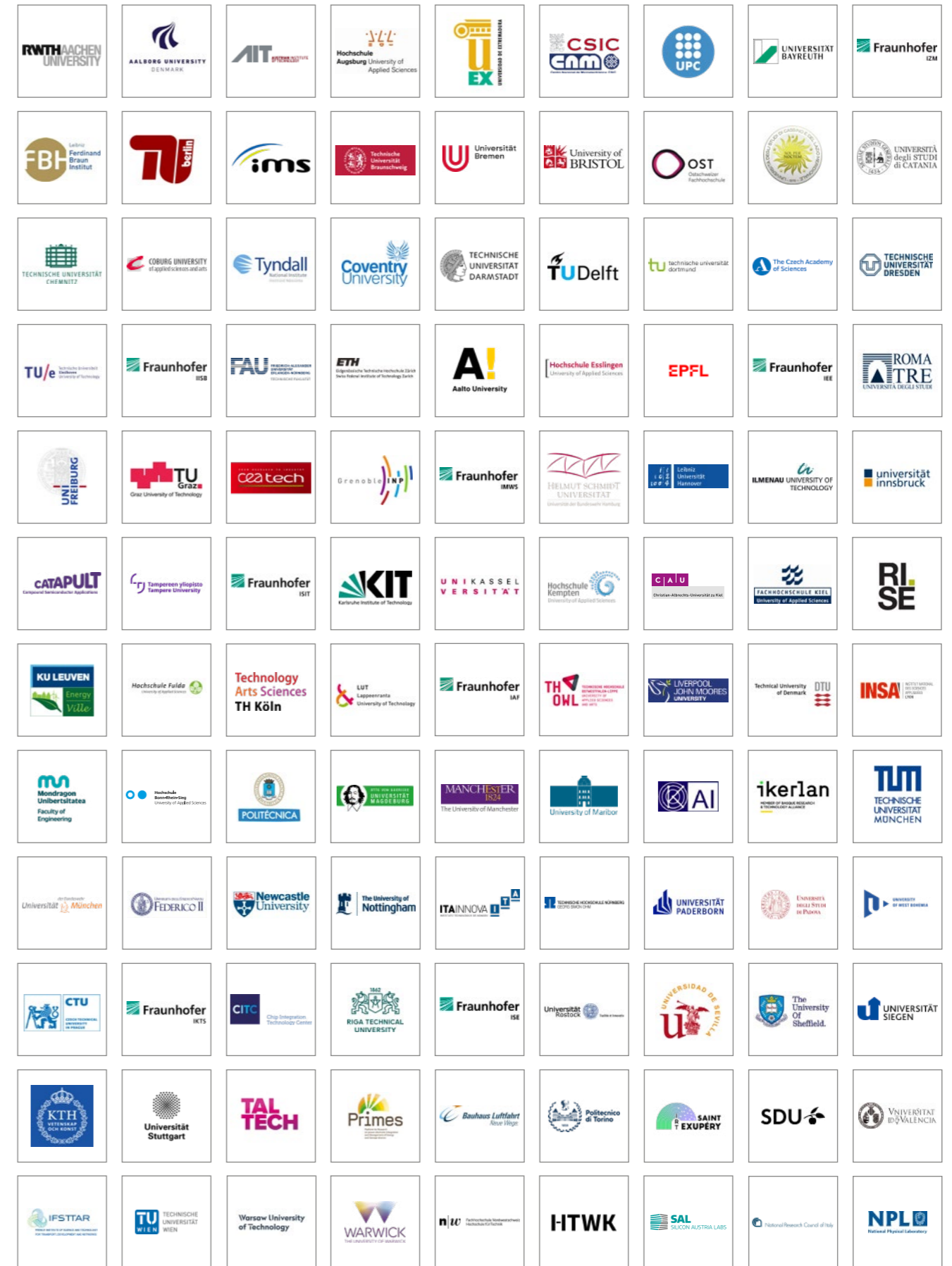

ECPE Joint Research Programme

In the network-internal research programme ECPE member companies jointly agree on pre-competitive research topics which are contracted to ECPE Competence Centres. The budget comes from an industrial research fund fed by the ECPE companies who took the option to join the research programme as Principal resp. Associate Partner. The Competence Centres are invited to submit research topics in an annual Call-for-Proposals.

Main benefit for the companies: cost sharing and discussion of latest research topics with university and research institutes as well as with companies along the value chain of power electronics

Main benefit for the institutes: funding opportunities and close cooperation with European power electronics industry

Procedure: from the project idea to the final report/demonstrator

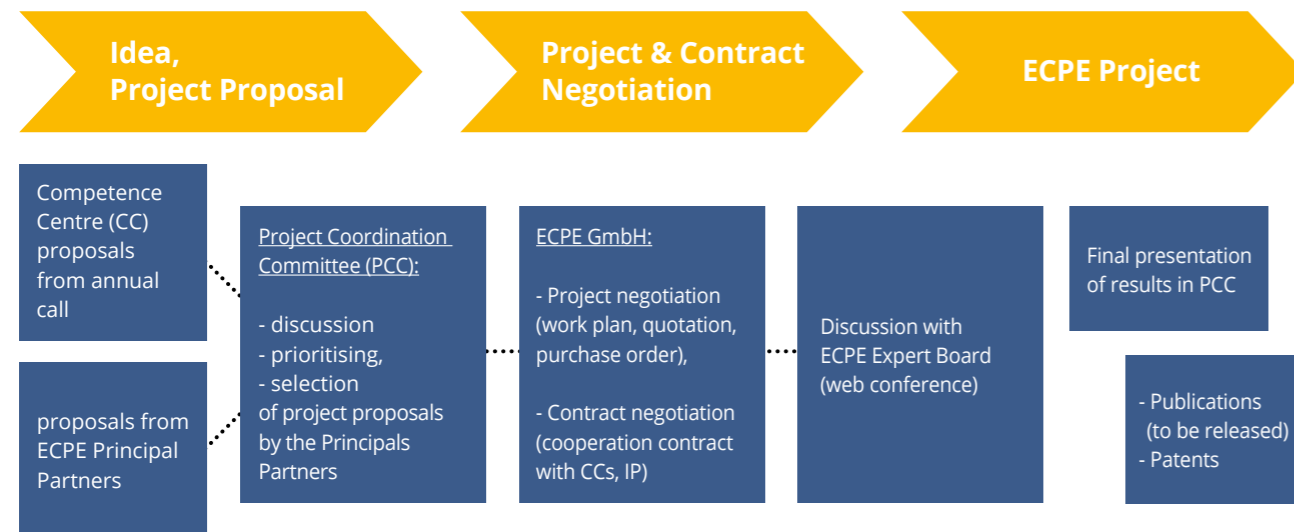

Example:

ECPE Lighthouse Programme msPEBB
- modular and scalable Power Electronic Building Block

SiC module:

Pre-packages (PowerCSPs) using PCB embedding technology

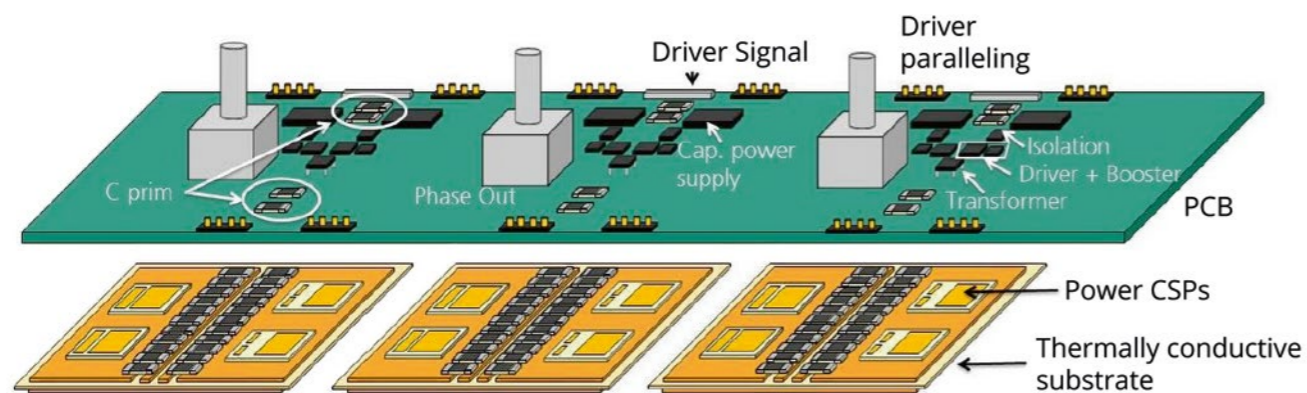

ECPE Working Groups

ECPE AQG 324 'Automotive Qualification Guideline'

The ECPE Working Group AQG 324 established in 2017 is working on a European Qualification Guideline for Power Modules for Use in Power Electronics Converter Units in Motor Vehicles. Based on the former German LV 324 supply agreement, the ECPE Guideline defines a common procedure for power module testing incl. environmental and lifetime testing of power electronic modules for automotive application. The guideline is released by the Industrial

Working Group comprising more than 30 ECPE member companies from the automotive supply chain. The present Guideline AQG 324 Release 03.1/2021 from 31 May 2021 covers Si-based power modules while SiC modules are addressed in a specific annex. Current working topics of the AQG 324 group include GaN-based power modules as well as novel assembly and interconnection technologies including power embedding.

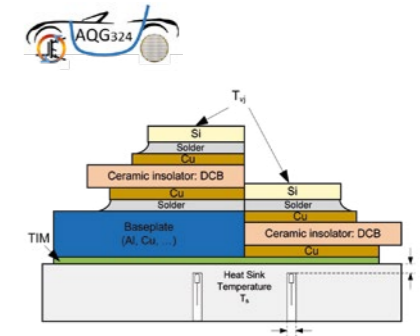

Power Semiconductor Reliability for Railway Application

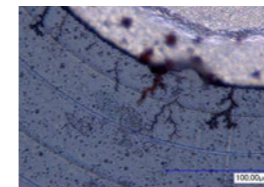

The ECPE Working Group on 'Power Semiconductor Reliability for Railway Application' has been established in November 2017 in cooperation with the PINTA Project in the European Shift2Rail Joint Undertaking. It comprises power semiconductor and module manufacturers as well as

companies from railway application on converter level, rolling stock and railway infrastructure. The Working Group has released an ECPE Guideline on High Voltage-H3TRB tests for power electronic Si IGBT and SiC MOSFET modules in the range of 1.7 - 6.5 kV for the use in rolling stock applications.

ECPE Roadmap Programme

Research and Technology Roadmaps are an important strategic tool to identify and guide a mainstream for medium to long term research. The ECPE Roadmaps 'Power Electronics 2025' and 'Lead Applications for SiC and GaN' provide input and industrial

guidance to research programmes on European and on national level. Furthermore, ECPE Members can reflect their own company roadmap vs. the ECPE roadmaps and the Competence Centres use the roadmaps when they define new research directions.

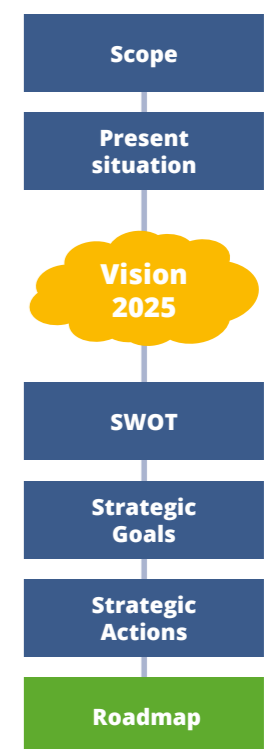
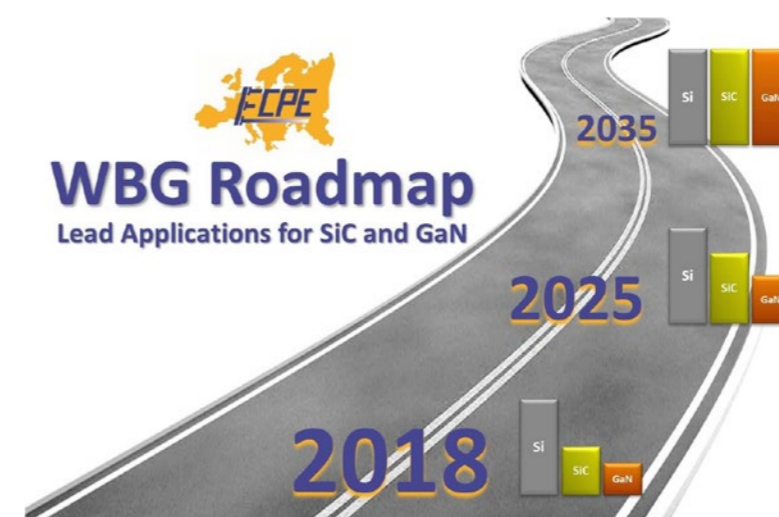

ECPE Programme 'Young Engineers Needed'

European PhD School

The European PhD School on 'Power Electronics, Electrical Machines, Energy Control and Power Systems' was founded in 1999 with the goal of providing PhD students with the opportunity to broaden their knowledge. As partner and sponsor ECPE is supporting the PhD school with the acquisition of speakers from industry and organizes the Industry Day for Recruitment. Moreover ECPE sponsors the European PhD School Poster Award.



ECPE Job Forum

FREE for ECPE Members

ECPE Job Forum

In the Job Forum on www.ecpe.org network members have the possibility to publish open positions in the field of power electronics free of charge. In addition, there is a separate rubric for student positions for practical trainings, master thesis or working students.

ECPE Students Day

One activity within the 'Young Engineers Needed' Programme is the ECPE Students Day organized in the frame of the PCIM Europe Exhibition.

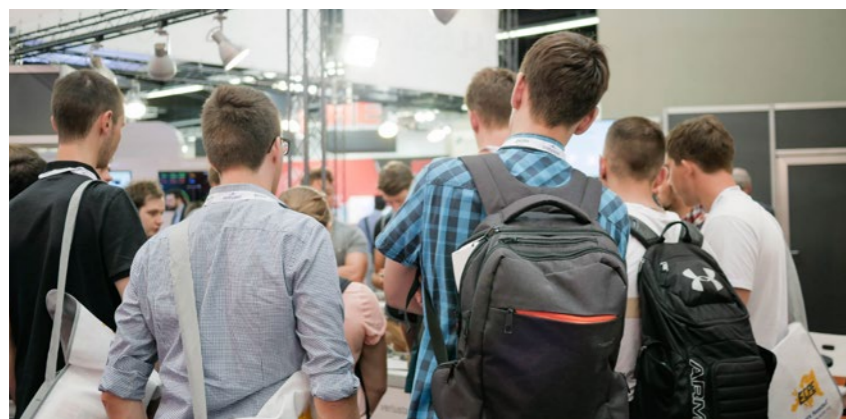

Contact

ECPE Board of Directors

Peter Beckedahl (SEMIKRON International), **Dr. Peter Friedrichs** (Infineon Technologies), **Matthias Hammerl** (Vitesco Technologies), **Prof. Dr. Rolf Hellinger** (Siemens), **Prof. Dr. Leo Lorenz**, **Philippe Loizelet** (Schneider Electric), **Dr. Torsten Leifert** (Volkswagen), **Dr. Peter Steimer** (Hitachi Energy), **Orhan Toker** (Plexim), **Dr. Stefan Weber** (TDK Electronics)

ECPE Staff

Dipl.-Phys. Thomas Harder
General Manager

Tel.: +49 (0) 911 / 810 288 - 11
Mail: thomas.harder@ecpe.org

Ingrid Bollens
Assistant

Tel.: +49 (0) 911 / 810 288 - 10
Mail: ingrid.bollens@ecpe.org

Dr. Chris Gould
Expert Power Electronics
Research Projects & Events

Tel.: +49 (0) 911 / 810 288 - 21
Mail: chris.gould@ecpe.org

M.Sc. Gudrun Feix
Expert Power Electronics
Research Projects & Events

Tel.: +49 (0) 911 / 810 288 - 15
Mail: grudrun.feix@ecpe.org

Dr.-Ing. Bernd Bitterlich
Clustermanager

Tel.: +49 (0) 911 / 810 288 - 14
Mail: bernd.bitterlich@ecpe.org

M.Sc. Peter Rechberger
Project Manager Cluster
Internationalization

Tel.: +49 (0) 911 / 810 288 - 12
Mail: peter.rechberger@ecpe.org

Dipl.-Btrw. (FH) Sabrina Haberl
Marketing & Member Service

Tel.: +49 (0) 911 / 810 288 - 13
Mail: sabrina.haberl@ecpe.org

Lena Somschor
Events & Website

Tel.: +49 (0) 911 / 810 288 - 18
Mail: lena.somschor@ecpe.org

Thomas Bollens
Financial Controlling

Tel.: +49 (0) 911 / 810 288 - 20
Mail: thomas.bollens@ecpe.org

Angela von der Grün
Events & Website

Tel.: +49 (0) 911 / 810 288 - 17
Mail: angela.vondergruen@ecpe.org

Krista Schmidt
Events & Secretary

Tel.: +49 (0) 911 / 810 288 - 16
Mail: krista.schmidt@ecpe.org