



European Center for Power Electronics

ECPE Demonstrator Programs



Co-financed by the European Union (structural fund Ziel 2) and by High-Tech-Offensive Bavaria



ECPE Objectives



● **Precompetitive Research in Power Electronic Systems**

- ECPE Demonstrator Projects with focus on automotive & industrial power electronic systems
- EC (or national) funded research projects with partners from the Network

● **Education & Advanced Training**

Expert seminars, workshops and online course for engineers in industry

● **Public Relations & Lobbying for Power Electronics**

Have “one strong voice” of power electronics industry to public & politics

ECPE Joint Research



Focussed and Prioritised Research in Power Electronics

- **Technology Studies in 2003/2004:**
 - ⇒ Industry Motor Drives, Automotive, System Integration
- **ECPE Demonstrator Projects in 3 main areas of Power Electronics:**
 - ⇒ **Industrial Drives – System Integration**
Volume reduction by system integration (e.g. 3D passive integration)
Competence Center-Partners: TU Delft / RWTH Aachen
 - ⇒ **Automotive Power Electronics (Mechatronic System)**
System integrated drive for Hybrid Traction
Competence Center-Partners: FhG IISB Erlangen-Nürnberg (FhG ISIT)
 - ⇒ **Power Supplies with Ultra-high Power Density**
High Frequency Power Electronics
Competence Center-Partner: ETH Zurich

- **Extremely compact converter** (power density several times higher compared to commercial converters)
- **Development of the key technologies** focused on:
 - compact design;
 - manufacturability;
 - cost.
- **Proven by demonstrator development** (2.2 kW demonstrator).

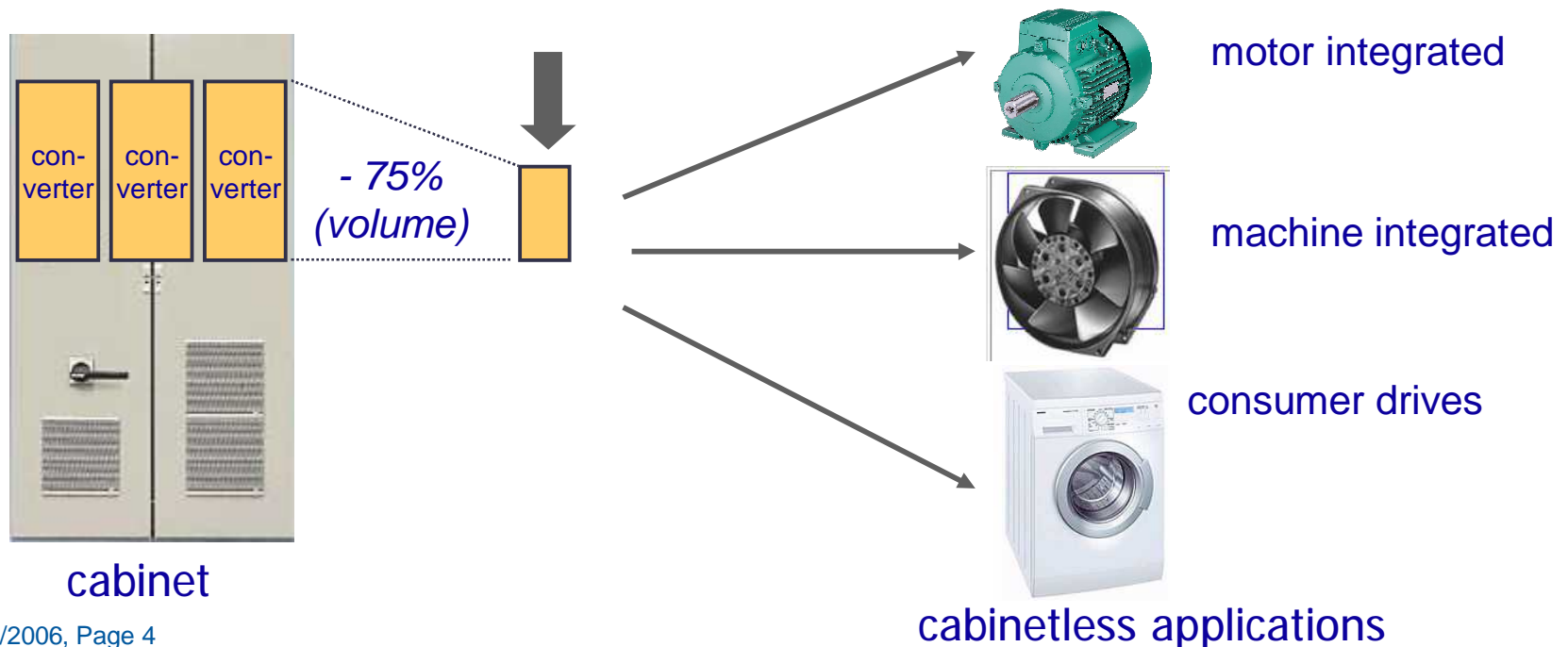



- **What is the volume in state-of-the-art drives being used for?**

Survey:

- Ø 60%: air and heat sink (forced air cooling)
- Ø 25%: packaging material
- Ø 15%: functional parts

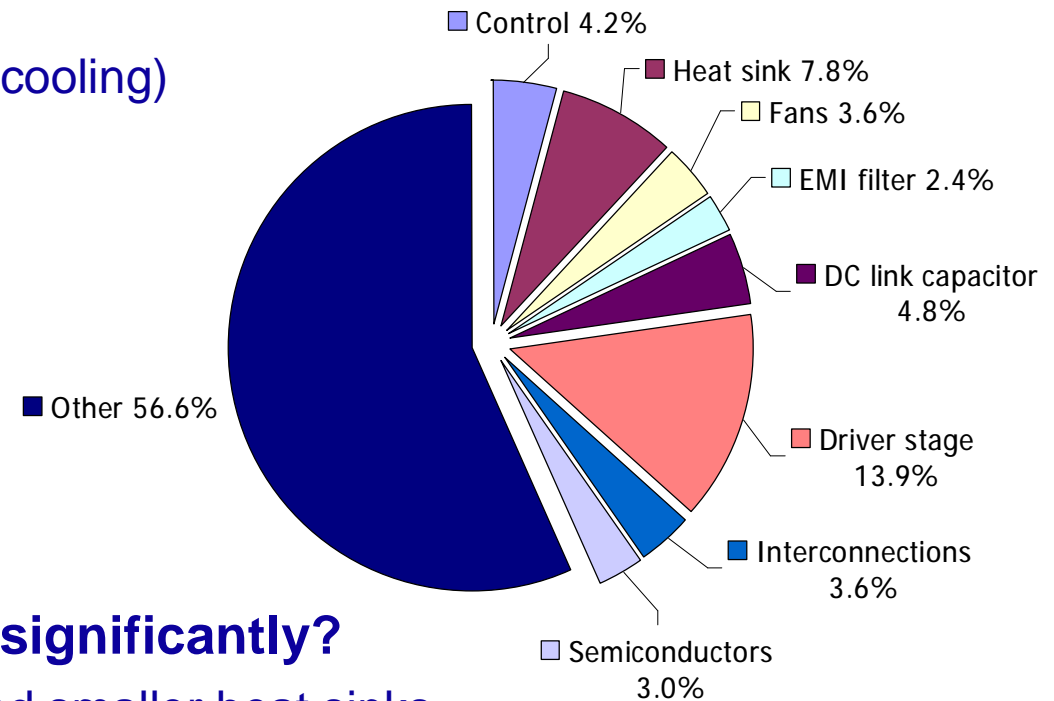

- **How can we reduce the volume significantly?**

- Ø Improved cooling using less air and smaller heat sinks
- Ø More efficient packaging by increasing the integration level



- **New system integration concept based on:**
 - ∅ **Hybrid IPEM integration** (Integrated Power Electronic Modules)
 - Circuit partitioned into three sub-circuits (system components)
 - Based on electrical and thermal characteristics of the sub-circuit
 - Each sub-circuit manufactured in suitable integration technology
 - ∅ **Advanced thermal management concept**
 - Integrated converter housing (I-Housing);
 - ∅ **New integration technologies for passive integration**
 - Multifunctional components and reduced packaging;
 - New electrical and thermal jointing techniques.

- **System components – Integrated Power Electronic Modules (IPEMs)**
 - ∅ **Planar Ceramic IPEM** – Ceramic substrate containing high heat density power semiconductor devices;
 - ∅ **Planar PCB IPEM** – PCB containing electronic control circuitry, auxiliary power supplies and gate drive circuitry;
 - ∅ **3D Passive IPEM** – contain large passive components (low pass filter and EMI filter) → needs new integration concepts: main focus of integration.

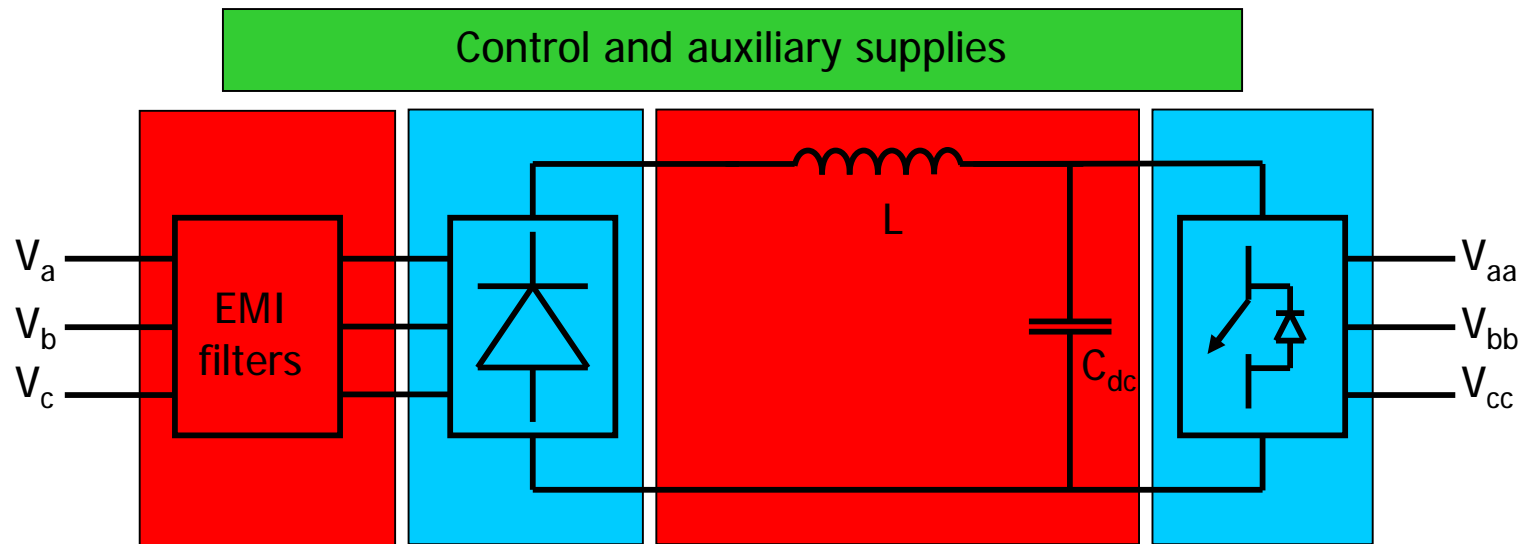

- **Integrated converter housing (I-housing)**
 - Ø Aluminium casing containing the three IPEMs;
 - Ø Heat collector and heat sink for the three IPEMs;
 - Ø Forced air cooled using a fan.
- **Shape and profile designed for optimal heat removal**
 - Ø Several I-housing concepts compared on the basis of heat transfer capability and manufacturability;
 - Ø Concept tested experimentally and proven feasible ($\Delta T < 50\text{ }^{\circ}\text{C}$, $T_{\text{amb}} = 50\text{ }^{\circ}\text{C}$).

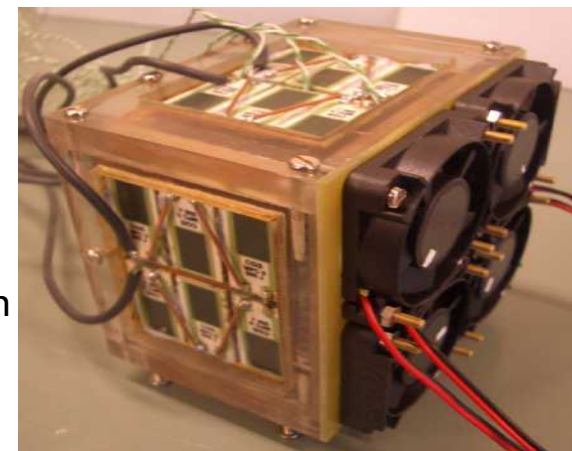
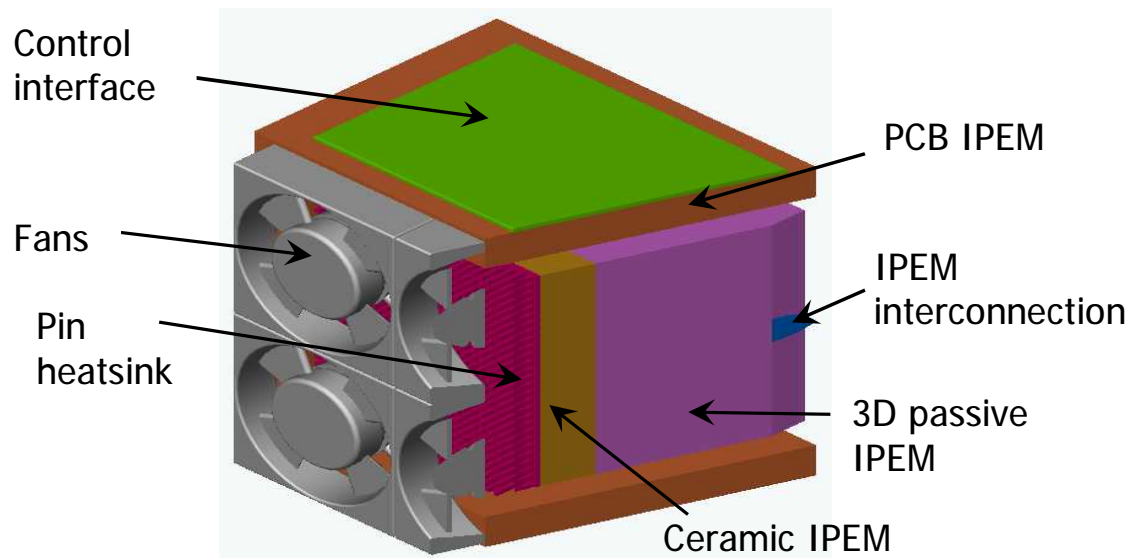



- **Passive components in state-of-the-art converters**
 - Ø Discrete components assemblies
 - Ø Bulky, not spatially designed to fit with each other
 - Volume occupied by air and packaging parts.
- **Higher levels of integration – fewer parts & smaller volume**
- **Electromagnetic passives integration technology**
 - Ø Planar ceramic integrated passives (CPES)
 - energy density not high enough for this application.
 - Ø Electrolytic capacitor technology?

System Integrated Drive for Hybrid Traction



Hybrid Traction in Automotive:

- Reduce fuel consumption and pollutant emissions
- Increase driving comfort and vehicle dynamic
- Develop system components that meet the tough requirements of the automotive industry with respect to
 - Compatibility with existing vehicle powertrains in terms of Size
 - Ambient conditions (temperature, vibration, contamination, etc.)
 - Costs
 - Reliability



System Integrated Drive for Hybrid Traction



Demonstrator concept

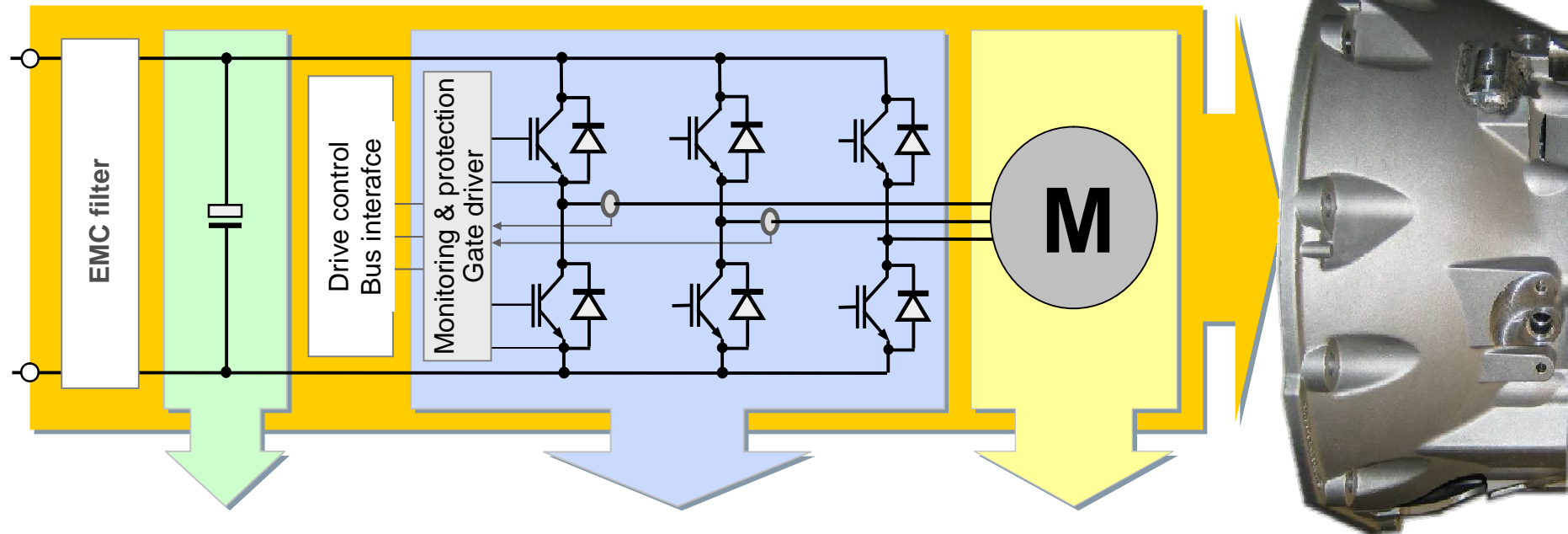

DC-Link

- § Voltage: 300...450V
- § Capacitor: $\approx 500\mu\text{F}$

3F-IGBT Bridge

- § 600V - IGBT
- § 450A peak (@ 115°C)
- § Integrated cooling
- § Current sensors

PM Machine

- § Peak power: 50 kW
- § Pairs of poles: 8
- § Max. torque: 220 Nm
- § Max. speed: 6000 rpm

System Integrated Drive for Hybrid Traction



Requirements for power electronics used in the automotive powertrain:

- Coolant temperature up to 115°C
- Ambient temperature in the engine compartment up to 140°C
- High currents (several 100A)
- High voltages in the range of 200V...450V
- Very small and cleaved mounting volume
- High vibrational load
- Tough reliability requirements
- Very low cost targets

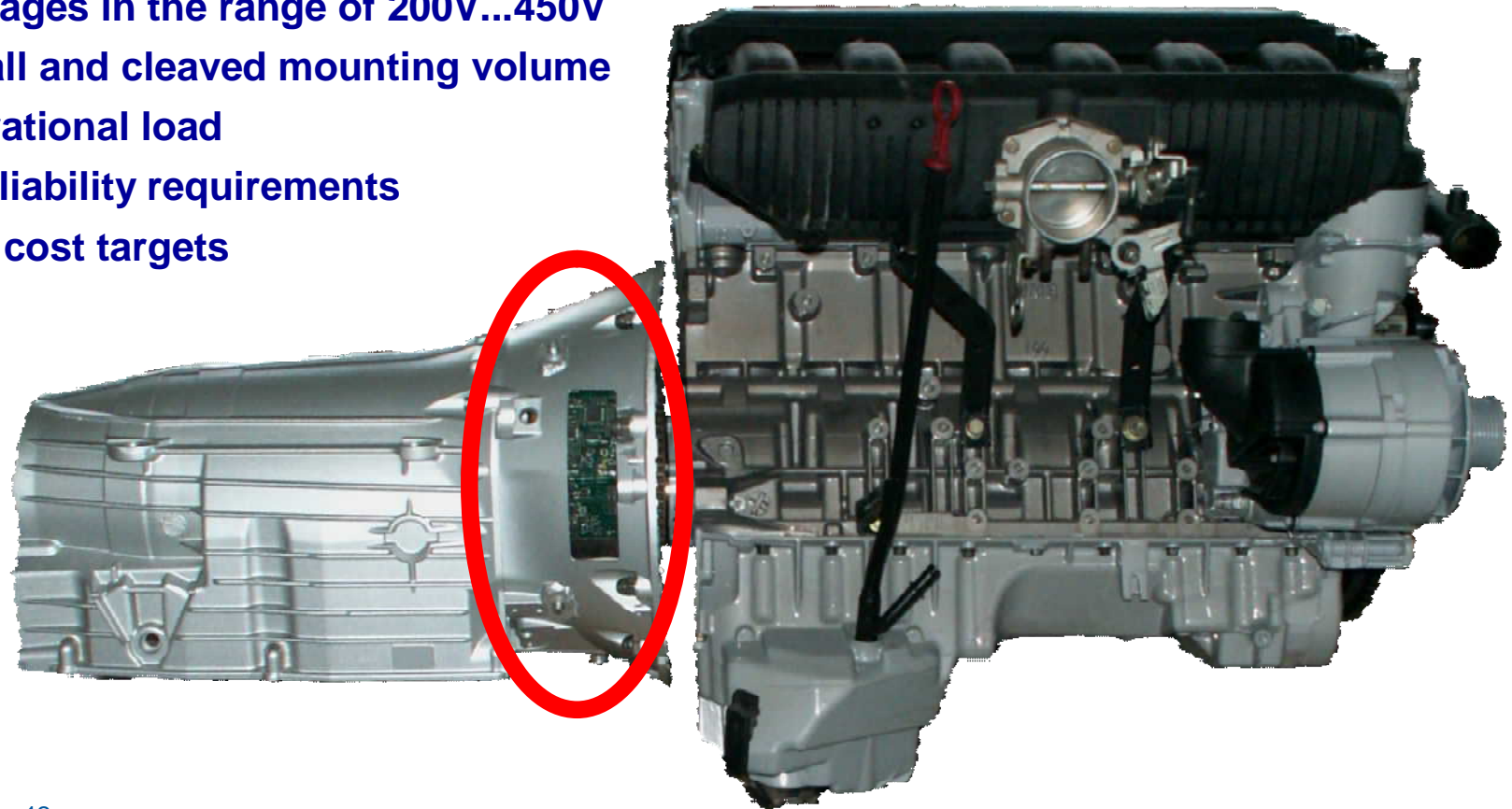

System Integrated Drive for Hybrid Traction



Demonstrator concept

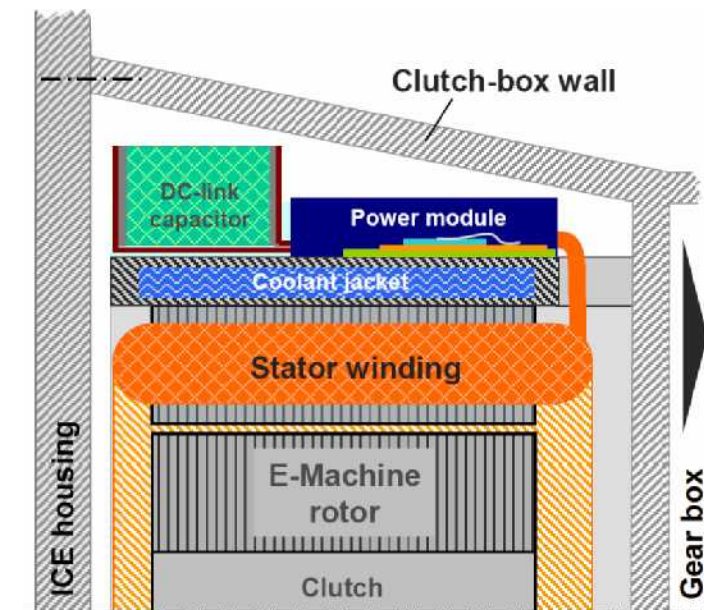
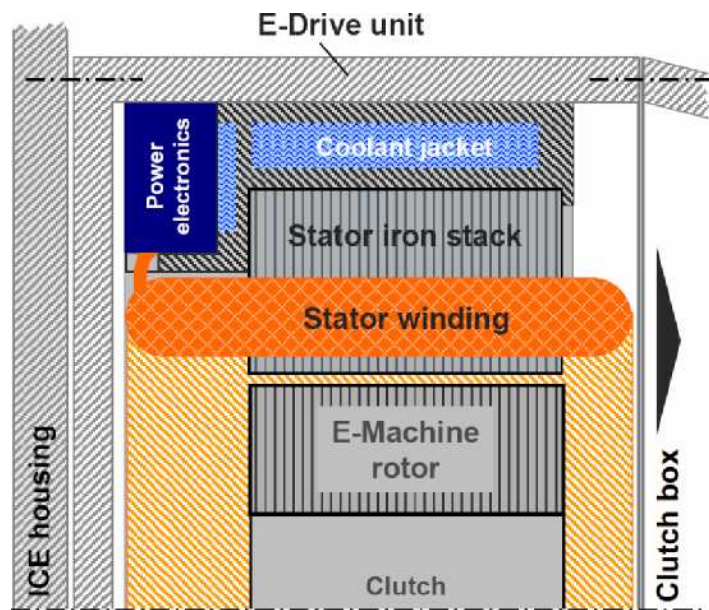

- larger diameter/ torque of motor possible
- separate cooling for electronics and motor
- Relatively simple mechanical construction
- **Power electronics close to hot windings**
- **Poor internal EMI conditions**

- Very good thermal decoupling
- Very effective cooling for motor and electronics
- Close to real clutch box geometry
- **Very strangely shaped volume for the power electronics**

System Integrated Drive for Hybrid Traction



Demonstrator concept

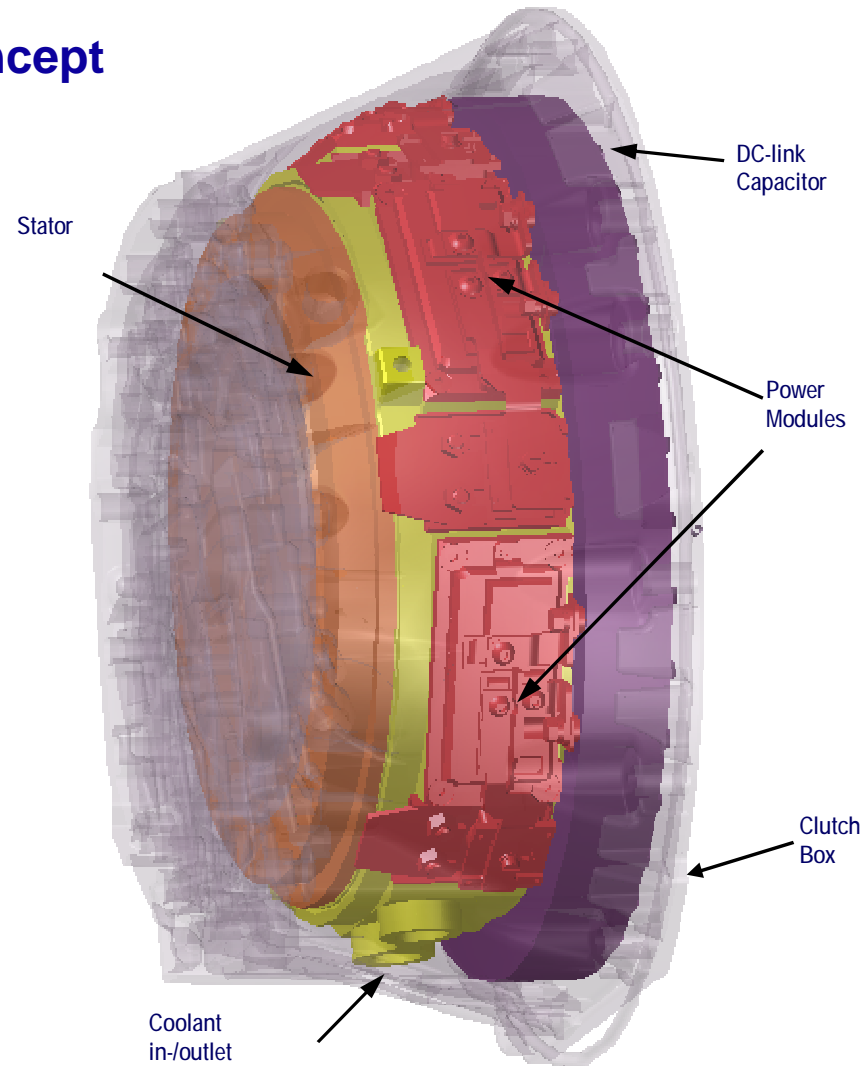

System Integrated Drive for Hybrid Traction



Power Modules:

- Compact halfbridge module
- Integrated gate driver electronics with error handling
- Electrical characterisation: $320A_{RMS}$ @ 400V

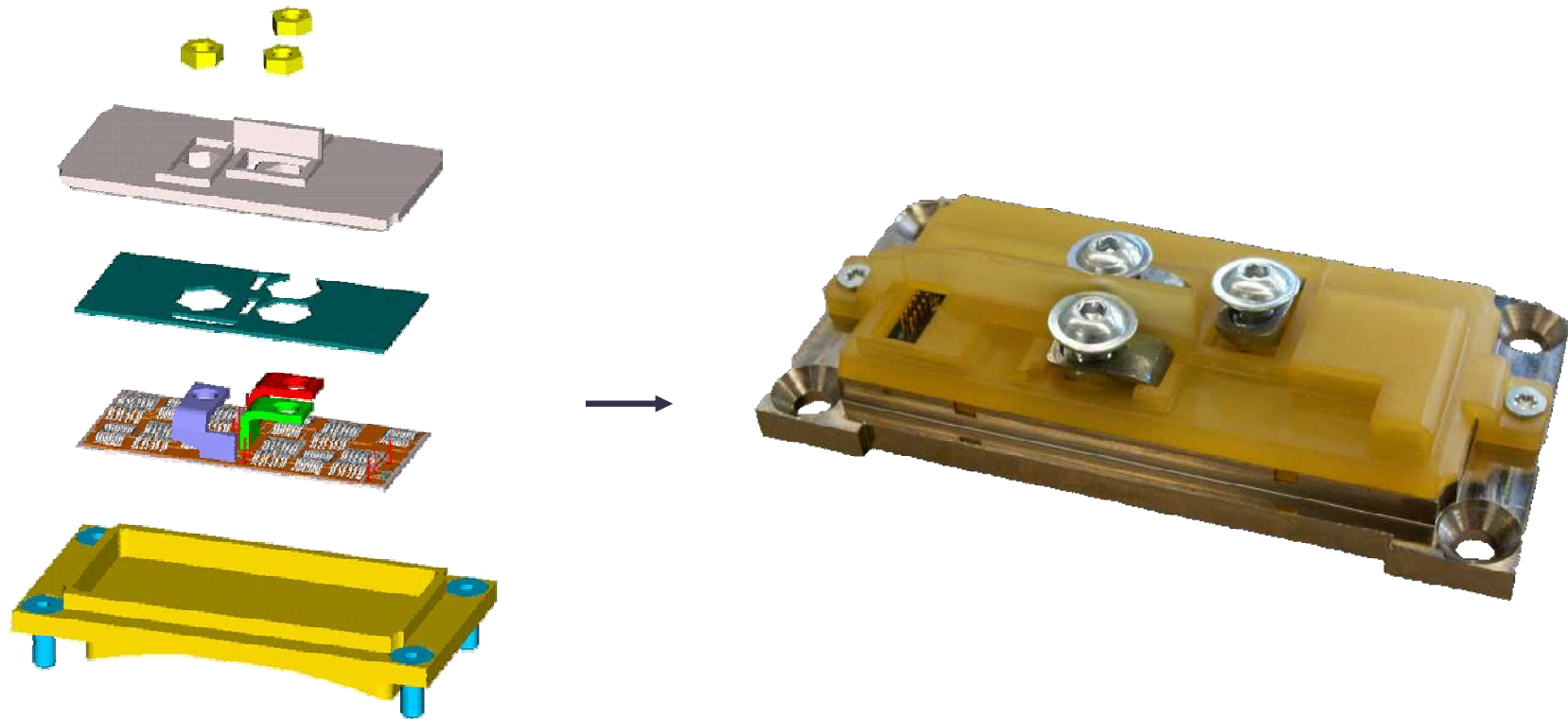

System Integrated Drive for Hybrid Traction



Demonstrator Status:

- Measurements on motor test bench
- Design of improved power modules

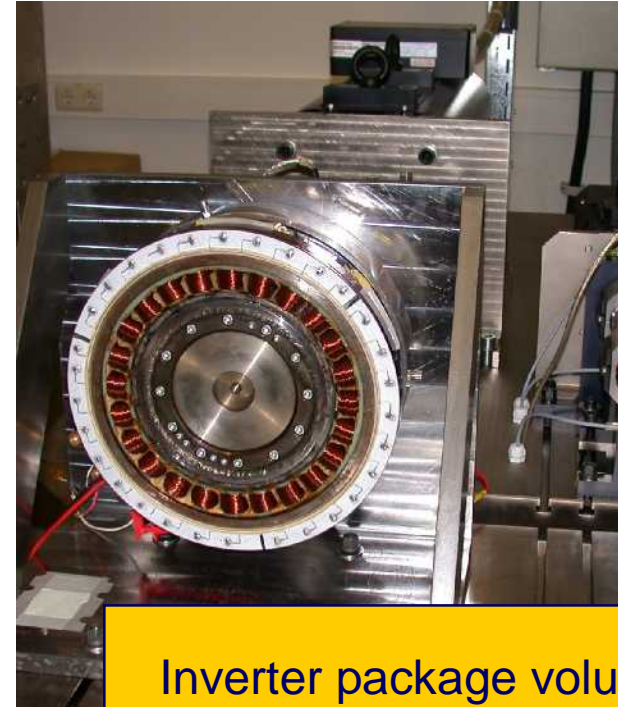
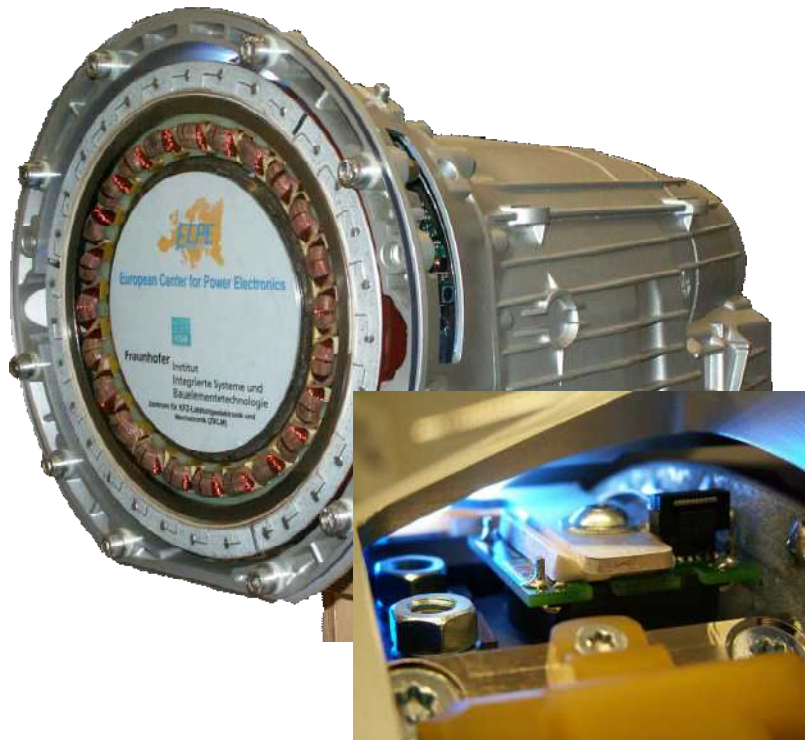

Inverter package volume: 1.3 dm³

Max. apparent power: 100 kVA

Power Density

75 kVA/dm³

(ca. 1.2 kVA/in³)

Power Supplies



- § **Aim:** To develop an ultra-compact three-phase AC-DC isolated power supply
- § Achieve a power density of **10 kW/litre** (164 W/cubic inch)
- § Will require new technology developments

- § **Project steps**
 1. Develop a 10 kW/l 3-phase AC-to-DC power factor corrected rectifier
 2. Develop a 10 kW/l DC-DC isolated converter (400V to 48V)
 3. Develop a complete power supply that achieves 10 kW/l by combining project steps 1 & 2



§ Project 1: AC-DC rectifier with 10 kW/l completed

- Ø Power density achieved
- Ø High frequency operation (up to 500 kHz)
- Ø Direct 3-phase boost topology
($800V_{DC}$ output)

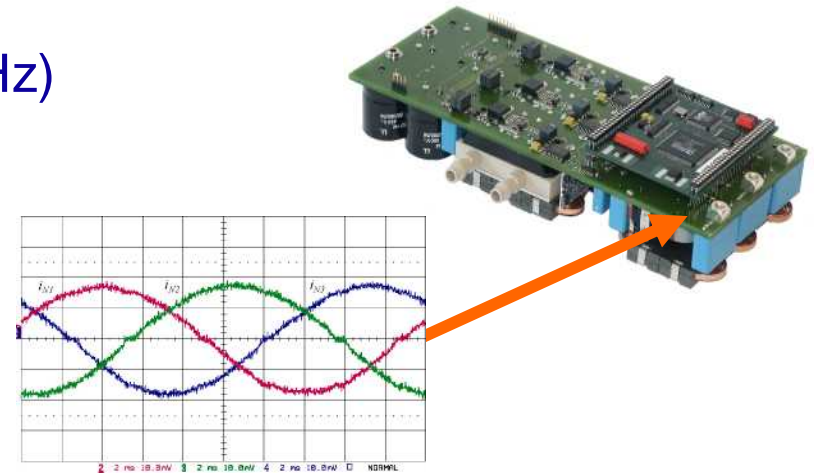

§ Project 2: DC-DC isolated converter has commenced

Project 1 - Rectifier Requirements

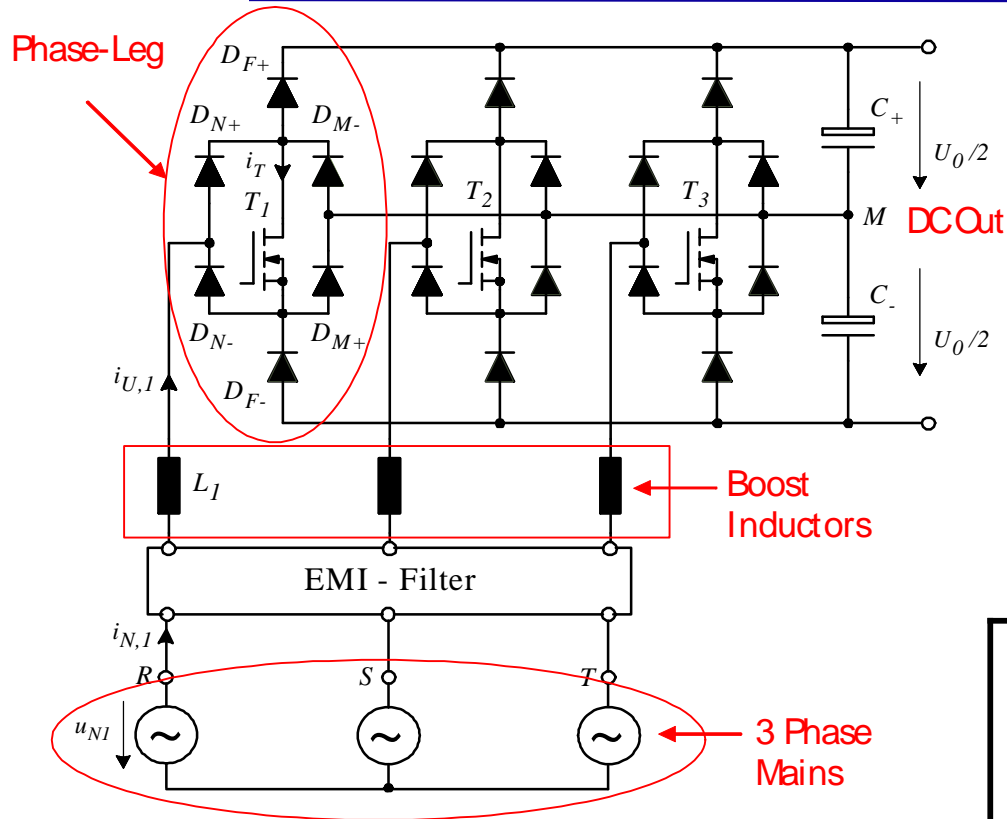

Active Rectifier (*Vienna Rectifier*) Topology

§ Challenge: Volume reduction with highest efficiency

§ high Power Density (10 kW/litre)

§ sinusoidal input currents

§ low volume EMI input filter

§ phase loss operation

è Use a 3-phase, 3-switch, 3-level active PFC boost rectifier (*Vienna Rectifier*)

Specification

input voltage: $U_{N,II}=320V...480V$

output voltage: $U_0=800V$ (controlled)

output voltage ripple: $\Delta U_{0,ss} < 0.1U_0$

output power: $P_0=10kW$

efficiency: $\eta > 95\%$ @ P_0

mains current distortion: $THD < 5\%$ @ P_0

Project 1 - Demonstrator Highlights

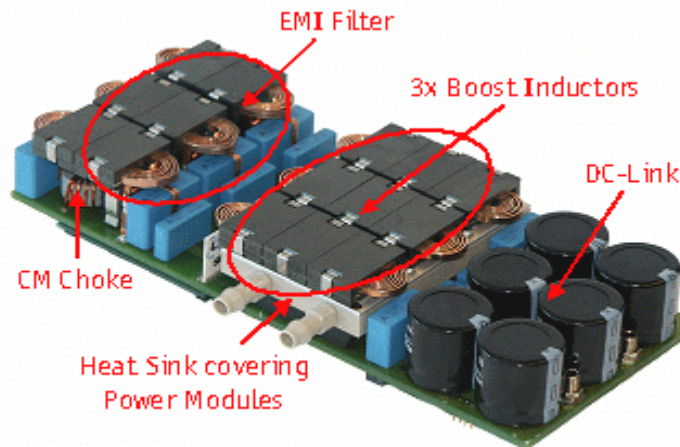
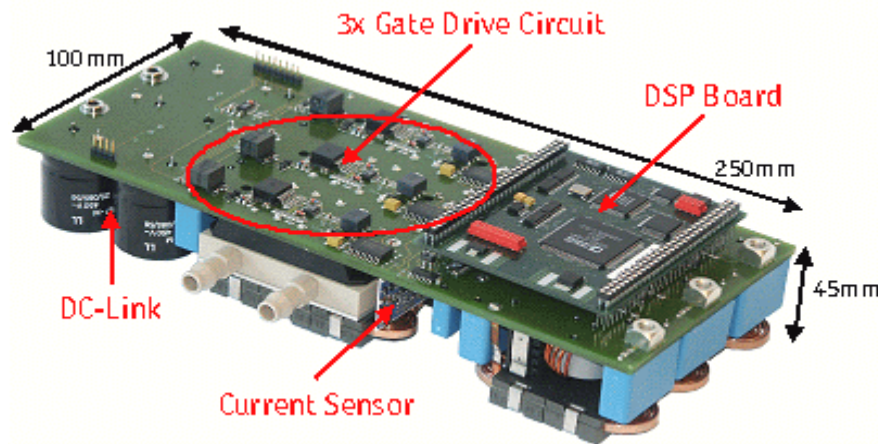

- § High switching frequency
- up to 500 kHz
- § Low volume magnetics
(boost inductor, EMI filter)
- § Use of latest semiconductors
(CoolMOS, SiC Schottky diodes)
- § Design of ultra fast gate driver using
magnetic couplers
- § Low volume/high bandwidth
magneto-resistive current sensors
- § Efficient cooling: optimized water
cooling heat sink
- § Digital control from a
custom DSP control board
- § Phase loss operation

Project 1 - Performance

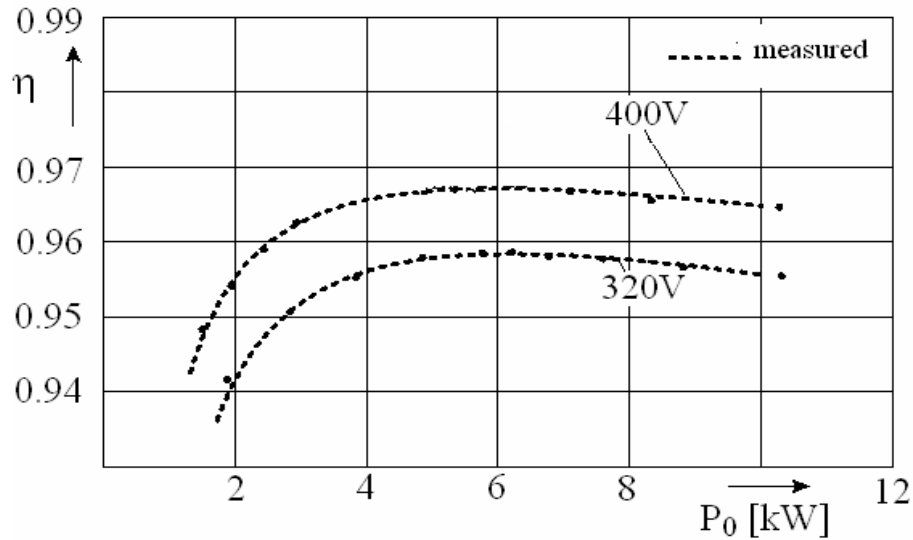

Efficiency vs. output power P₀

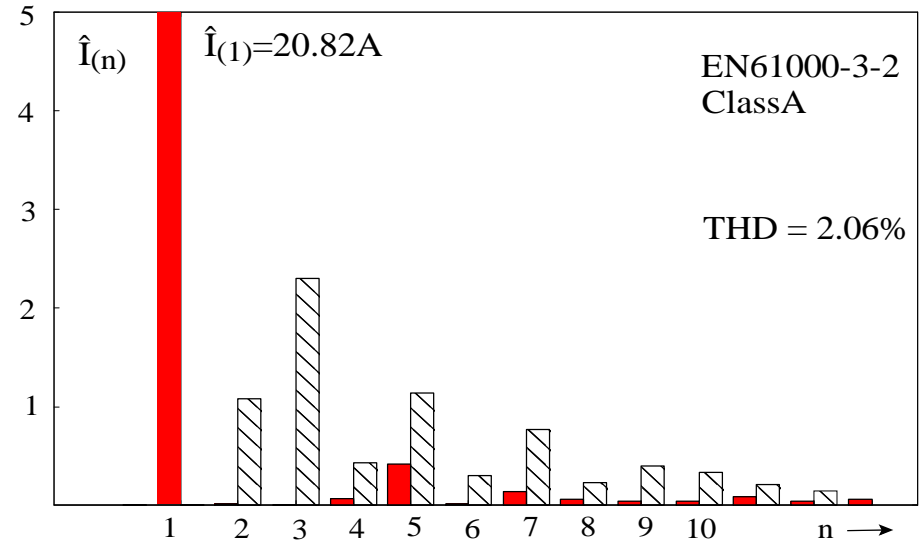

THD: Mains current amplitude vs. harmonics @ P₀=10 kW

§ Performance exceeds requirements

Ø Efficiency > 96%, P₀ = 3...10 kW

Ø THD = 2% @ P₀ = 10kW